Stream: Internet Engineering Task Force (IETF)
RFC: [9656](#)
Category: Standards Track
Published: September 2024
ISSN: 2070-1721
Authors: S. Mansfield, Ed. J. Ahlberg M. Ye
Ericsson Inc Ericsson AB Huawei Technologies
X. Li D. Spreafico
NEC Laboratories Europe Nokia - IT

RFC 9656

A YANG Data Model for Microwave Topology

Abstract

This document defines a YANG data model to describe microwave and millimeter-wave radio links in a network topology.

Status of This Memo

This is an Internet Standards Track document.

This document is a product of the Internet Engineering Task Force (IETF). It represents the consensus of the IETF community. It has received public review and has been approved for publication by the Internet Engineering Steering Group (IESG). Further information on Internet Standards is available in Section 2 of RFC 7841.

Information about the current status of this document, any errata, and how to provide feedback on it may be obtained at <https://www.rfc-editor.org/info/rfc9656>.

Copyright Notice

Copyright (c) 2024 IETF Trust and the persons identified as the document authors. All rights reserved.

This document is subject to BCP 78 and the IETF Trust's Legal Provisions Relating to IETF Documents (<https://trustee.ietf.org/license-info>) in effect on the date of publication of this document. Please review these documents carefully, as they describe your rights and restrictions with respect to this document. Code Components extracted from this document must include Revised BSD License text as described in Section 4.e of the Trust Legal Provisions and are provided without warranty as described in the Revised BSD License.

Table of Contents

1. Introduction	3
1.1. Abbreviations	3
1.2. Tree Structure	4
1.3. Prefixes in Data Node Names	4
2. Microwave Topology YANG Data Model	4
2.1. YANG Tree	4
2.2. Relationship between Radio Links and Carriers	5
2.3. Relationship with Client Topology Model	5
2.4. Applicability of the Data Model for Traffic Engineering (TE) Topologies	6
2.5. Microwave Topology YANG Module	6
3. Security Considerations	12
4. IANA Considerations	12
5. References	13
5.1. Normative References	13
5.2. Informative References	13
Appendix A. Microwave Topology Model with Base Topology Models	14
A.1. Instance Data for 2+0 Mode for a Bonded Configuration	17
A.2. Instance Data for 1+1 Mode for a Protected Configuration	22
Appendix B. Microwave Topology Model with Example Extensions	27
B.1. Instance Data for 2+0 Mode	30
B.2. Instance Data for Geolocation Information	38
Acknowledgments	38
Contributors	39
Authors' Addresses	39

1. Introduction

This document defines a YANG data model to describe microwave and millimeter-wave radio links in a network topology (hereafter, "microwave" is used to simplify the text). The YANG data model describes radio links, supporting carrier(s), and the associated carrier termination points [RFC8561]. A carrier is a single link providing transport capacity over the air. It is typically defined by its transmitting and receiving frequencies. A radio link provides the transport capacity of the supporting carriers in aggregated and/or protected configurations, which can be used to carry traffic on higher topology layers such as Ethernet and Time-Division Multiplexing (TDM). The model augments the [YANG Data Model for Traffic Engineering \(TE\) Topologies](#) defined in [RFC8795], which is based on [A YANG Data Model for Network Topologies](#) defined in [RFC8345].

The microwave point-to-point radio technology provides connectivity on Layer 0 or Layer 1 (L0/L1) over a radio link between two termination points using one or several supporting carriers in aggregated or protected configurations. That application of microwave technology cannot be used to perform cross-connection or switching of the traffic to create network connectivity across multiple microwave radio links. Instead, a payload of traffic on higher topology layers, normally Layer 2 (L2) Ethernet, is carried over the microwave radio link. When the microwave radio link is terminated at the endpoints, cross-connection and switching can be performed on that higher layer creating connectivity across multiple supporting microwave radio links.

The microwave topology model is expected to be used between a Provisioning Network Controller (PNC) and a Multi-Domain Service Coordinator (MDSC) [RFC8453]. Examples of use cases that can be supported are:

1. Correlation between microwave radio links and the supported links on higher topology layers (e.g., an L2 Ethernet topology). This information can be used to understand how changes in the performance/status of a microwave radio link affect traffic on higher layers.
2. Propagation of relevant characteristics of a microwave radio link, such as bandwidth, to higher topology layers, where it could be used as a criterion when configuring and optimizing a path for a connection or service through the network end to end.
3. Optimization of the microwave radio link configurations on a network level, with the purpose to minimize overall interference and/or maximize the overall capacity provided by the links.

1.1. Abbreviations

The following abbreviations are used in this document:

CTP: Carrier Termination Point

RLT: Radio Link Terminal

RLTP: Radio Link Termination Point

1.2. Tree Structure

A simplified graphical representation of the data model is used in [Section 2](#) of this document. The meaning of the symbols in these diagrams is defined in [\[RFC8340\]](#).

1.3. Prefixes in Data Node Names

In this document, names of data nodes and other data model objects are prefixed using the standard prefix associated with the corresponding YANG imported modules, as shown in [Table 1](#).

Prefix	YANG Module	Reference
nw	ietf-network	[RFC8345]
nt	ietf-network-topology	[RFC8345]
mw-types	ietf-microwave-types	[RFC8561]
tet	ietf-te-topology	[RFC8795]

Table 1: Prefixes for Imported YANG Modules

2. Microwave Topology YANG Data Model

2.1. YANG Tree

```

module: ietf-microwave-topology

augment /nw:networks/nw:network/nw:network-types/tet:te-topology:
  +--rw mw-topology!
augment /nw:networks/nw:network/nw:node/tet:te
  /tet:te-node-attributes:
  +--rw mw-node!
augment /nw:networks/nw:network/nw:node/nt:termination-point
  /tet:te:
  +--rw mw-tp!
  +--rw (mw-tp-option)?
  +--:(microwave-rltp)
  | +--rw microwave-rltp!
  +--:(microwave-ctp)
  +--rw microwave-ctp!
augment /nw:networks/nw:network/nt:link/tet:te
  /tet:te-link-attributes:
  +--rw mw-link!
  +--rw (mw-link-option)
  +--:(microwave-radio-link)
  | +--rw microwave-radio-link!
  |   +--rw rlt-mode
  |     +--rw num-bonded-carriers          uint32
  |     +--rw num-protecting-carriers      uint32
  +--:(microwave-carrier)
  +--rw microwave-carrier!
  +--rw tx-frequency?                    uint32
  +--ro actual-rx-frequency?              uint32
  +--rw channel-separation?              uint32
  +--ro actual-tx-cm?                     identityref
  +--ro actual-snr?                       decimal64
  +--ro actual-transmitted-level?         decimal64
augment /nw:networks/nw:network/nt:link/tet:te
  /tet:te-link-attributes/tet:max-link-bandwidth
  /tet:te-bandwidth:
  +--ro mw-bandwidth?                    uint64

```

Figure 1: Microwave Topology Tree

2.2. Relationship between Radio Links and Carriers

A microwave radio link is always an aggregate of one or multiple carriers in various configurations or modes. The supporting carriers are identified by their termination points and are listed in the container-bundled links as part of the te-link-config in the [YANG Data Model for Traffic Engineering \(TE\) Topologies \[RFC8795\]](#) for a radio-link. The exact configuration of the included carriers is further specified in the rlt-mode container (1+0, 2+0, 1+1, etc.) for the radio-link. [Appendix A](#) includes JSON examples of how such a relationship can be modeled.

2.3. Relationship with Client Topology Model

A microwave radio link carries a payload of traffic on higher topology layers, normally L2 Ethernet. The leafs supporting-network, supporting-node, supporting-link, and supporting-termination-point in the generic YANG module for Network Topologies [\[RFC8345\]](#) are expected to

be used to model a relationship or dependency from higher topology layers to a supporting microwave radio link topology layer. [Appendix A](#) includes JSON examples of an L2 Ethernet link transported over one supporting microwave link.

2.4. Applicability of the Data Model for Traffic Engineering (TE) Topologies

Since microwave is a point-to-point radio technology, a majority of the leafs in the Data Model for Traffic Engineering (TE) Topologies [[RFC8795](#)] augmented by the microwave topology model are not applicable. Examples of which leafs are considered applicable can be found in [Appendices A](#) and [B](#) in this document.

In the more specific context of the microwave-specific augmentations of te-topology, the admin-status, and oper-status leafs (from te-topology) are only applicable to microwave carriers (in the mw-link tree); they are not applicable to microwave radio links. Radio links are instead enabled or disabled in the constituent carriers. Furthermore, the status leafs related to mw-tp can be used with inter-domain links and when the status of only one side of the link is known. However, since microwave is a point-to-point technology where both ends normally belong to the same domain, it is not expected to be applicable in normal cases.

2.5. Microwave Topology YANG Module

This module imports typedefs and modules from [[RFC8345](#)], [[RFC8561](#)], and [[RFC8795](#)]. It references [[EN301129](#)] and [[EN302217-1](#)].

```
<CODE BEGINS> file "ietf-microwave-topology@2024-09-30.yang"

module ietf-microwave-topology {
  yang-version 1.1;
  namespace "urn:ietf:params:xml:ns:yang:ietf-microwave-topology";
  prefix mwt;

  import ietf-network {
    prefix nw;
    reference
      "RFC 8345: A YANG Data Model for Network Topologies";
  }
  import ietf-network-topology {
    prefix nt;
    reference
      "RFC 8345: A YANG Data Model for Network Topologies";
  }
  import ietf-te-topology {
    prefix tet;
    reference
      "RFC 8795: YANG Data Model for Traffic Engineering
      (TE) Topologies";
  }
  import ietf-microwave-types {
    prefix mw-types;
    reference
      "RFC 8561: A YANG Data Model for Microwave Radio Link";
  }
}
```

```
organization
  "Internet Engineering Task Force (IETF) CCAMP WG";
contact
  "WG Web: <https://datatracker.ietf.org/wg/ccamp/>
  WG List: <ccamp@ietf.org>

  Editor: Jonas Ahlberg
    <jonas.ahlberg@ericsson.com>
  Editor: Scott Mansfield
    <scott.mansfield@ericsson.com>
  Editor: Min Ye
    <amy.yemin@huawei.com>
  Editor: Italo Busi
    <Italo.Busi@huawei.com>
  Editor: Xi Li
    <Xi.Li@neclab.eu>
  Editor: Daniela Spreafico
    <daniela.spreafico@nokia.com>
";
description
  "This is a module for microwave topology.

  Copyright (c) 2024 IETF Trust and the persons
  identified as authors of the code. All rights reserved.

  Redistribution and use in source and binary forms, with or
  without modification, is permitted pursuant to, and subject
  to the license terms contained in, the Revised BSD License
  set forth in Section 4.c of the IETF Trust's Legal Provisions
  Relating to IETF Documents
  (https://trustee.ietf.org/license-info).

  This version of this YANG module is part of RFC 9656; see
  the RFC itself for full legal notices.";

revision 2024-09-30 {
  description
    "Initial revision.";
  reference
    "RFC 9656: A YANG Data Model for Microwave Topology";
}

grouping rlt-mode {
  description
    "This grouping provides a flexible definition of the number
    of bonded carriers and protecting carriers of a radio
    link.";
  leaf num-bonded-carriers {
    type uint32;
    mandatory true;
    description
      "Number of bonded carriers.";
  }
  leaf num-protecting-carriers {
    type uint32;
    mandatory true;
    description
```

```
        "Number of protecting carriers.";
    }
}

grouping microwave-radio-link-attributes {
    description
        "Grouping used for attributes describing a microwave
        radio link.";
    container rlt-mode {
        description
            "This grouping provides a flexible definition of the number
            of bonded carriers and protecting carriers of a radio
            link.";
        uses rlt-mode;
    }
}

grouping microwave-carrier-attributes {
    description
        "Grouping used for attributes describing a microwave
        carrier.";
    leaf tx-frequency {
        type uint32;
        units "kHz";
        description
            "Selected transmitter frequency.
            Related to the data node tx-frequency in RFC 8561.";
        reference
            "RFC 8561: A YANG Data Model for Microwave Radio Link";
    }
    leaf actual-rx-frequency {
        type uint32;
        units "kHz";
        config false;
        description
            "Computed receiver frequency.
            Related to the data node actual-rx-frequency in RFC 8561.";
        reference
            "RFC 8561: A YANG Data Model for Microwave Radio Link";
    }
    leaf channel-separation {
        type uint32;
        units "kHz";
        description
            "The amount of bandwidth allocated to a carrier. The
            distance between adjacent channels in a radio
            frequency channel arrangement.
            Related to the data node channel-separation in RFC 8561.";
        reference
            "ETSI EN 302 217-1 and
            RFC 8561: A YANG Data Model for Microwave Radio Link";
    }
    leaf actual-tx-cm {
        type identityref {
            base mw-types:coding-modulation;
        }
        config false;
        description

```



```
        "Actual coding/modulation in transmitting direction.
        Related to the data node actual-tx-cm in RFC 8561.";
    reference
        "RFC 8561: A YANG Data Model for Microwave Radio Link";
}
leaf actual-snr {
    type decimal64 {
        fraction-digits 1;
    }
    units "dB";
    config false;
    description
        "Actual signal-to-noise plus the interference ratio
        (0.1 dB resolution).
        Related to the data node actual-snr in RFC 8561.";
    reference
        "RFC 8561: A YANG Data Model for Microwave Radio Link";
}
leaf actual-transmitted-level {
    type decimal64 {
        fraction-digits 1;
    }
    units "dBm";
    config false;
    description
        "Actual transmitted power level (0.1 dBm resolution).
        Related to the data node actual-transmitted-level
        in RFC 8561.";
    reference
        "ETSI EN 301 129 and
        RFC 8561: A YANG Data Model for Microwave Radio Link";
}
}

grouping microwave-bandwidth {
    description
        "Grouping used for microwave bandwidth.";
    leaf mw-bandwidth {
        type uint64;
        units "bits/seconds";
        config false;
        description
            "Nominal microwave radio link and carrier bandwidth.";
    }
}

augment "/nw:networks/nw:network/nw:network-types/"
    + "tet:te-topology" {
    description
        "Augment network types to define a microwave network
        topology type.";
    container mw-topology {
        presence "Indicates a topology type of microwave.";
        description
            "Microwave topology type";
    }
}
}
```

```

augment "/nw:networks/nw:network/nw:node/tet:te"
  + "/tet:te-node-attributes" {
  when '../..../nw:network-types'
  + '/tet:te-topology/mwt:mw-topology' {
    description
      "Augmentation parameters apply only to networks with a
      microwave network topology type.";
  }
  description
    "Augment network node to indicate a microwave node.";
  container mw-node {
    presence "Indicates a microwave node.";
    description
      "Microwave node";
  }
}

augment "/nw:networks/nw:network/nw:node/nt:termination-point/"
  + "tet:te" {
  when '../..../nw:network-types/tet:te-topology/'
  + 'mwt:mw-topology' {
    description
      "Augmentation parameters apply only for networks with a
      microwave network topology type.";
  }
  description
    "Augmentation to add microwave-technology-specific
    characteristics to a termination point.";
  container mw-tp {
    presence "Denotes a microwave termination point.";
    description
      "Specification of type of termination point.";
    choice mw-tp-option {
      description
        "Selection of type of termination point.";
      case microwave-rltp {
        container microwave-rltp {
          presence
            "Denotes a microwave radio link termination point.
            It corresponds to a microwave RLT interface as
            defined in RFC 8561.";
          description
            "Denotes and describes a microwave radio link
            termination point.";
          reference
            "RFC 8561: A YANG Data Model for Microwave Radio Link";
        }
      }
      case microwave-ctp {
        container microwave-ctp {
          presence "Denotes a microwave carrier termination point.
          It corresponds to a microwave CT interface as
          defined in RFC 8561.";
          description
            "Denotes and describes a microwave carrier
            termination point.";
          reference
            "RFC 8561: A YANG Data Model for Microwave Radio Link";
        }
      }
    }
  }
}

```

```

    }
  }
}

augment "/nw:networks/nw:network/nt:link/tet:te/"
  + "tet:te-link-attributes" {
  when '../..../nw:network-types/tet:te-topology/'
  + 'mwt:mw-topology' {
  description
    "Augmentation parameters apply only for networks with a
    microwave network topology type.";
  }
  description
    "Augmentation to add microwave-technology-specific
    characteristics to a link.";
  container mw-link {
  presence "This indicates a microwave link";
  description
    "Specification of type of link.";
  choice mw-link-option {
  mandatory true;
  description
    "Selection of type of link.";
  case microwave-radio-link {
  container microwave-radio-link {
  presence "Denotes a microwave radio link";
  description
    "Denotes and describes a microwave radio link.";
  uses microwave-radio-link-attributes;
  }
  }
  case microwave-carrier {
  container microwave-carrier {
  presence "Denotes a microwave carrier";
  description
    "Denotes and describes a microwave carrier.";
  uses microwave-carrier-attributes;
  }
  }
  }
}

augment "/nw:networks/nw:network/nt:link/tet:te/"
  + "tet:te-link-attributes/"
  + "tet:max-link-bandwidth/"
  + "tet:te-bandwidth" {
  when '../..../..../nw:network-types/tet:te-topology/'
  + 'mwt:mw-topology' {
  description
    "Augmentation parameters apply only for networks with a
    microwave network topology type.";
  }
  description
    "Augmentation for TE bandwidth.";
  uses microwave-bandwidth;
}

```

```
}  
}  
<CODE ENDS>
```

3. Security Considerations

The YANG module specified in this document defines schemas for data that is designed to be accessed via network management protocols such as NETCONF [RFC6241] or RESTCONF [RFC8040]. The lowest NETCONF layer is the secure transport layer, and the mandatory-to-implement secure transport is Secure Shell (SSH) [RFC6242]. The lowest RESTCONF layer is HTTPS, and the mandatory-to-implement secure transport is TLS [RFC8446].

The NETCONF access control model [RFC8341] provides the means to restrict access for particular NETCONF or RESTCONF users to a preconfigured subset of all available NETCONF or RESTCONF protocol operations and content.

The YANG module specified in this document imports and augments the ietf-network and ietf-network-topology models defined in [RFC8345]. The security considerations from [RFC8345] are applicable to the module in this document.

There are a number of data nodes defined in this YANG module that are writable/creatable/deletable (i.e., config true, which is the default). These data nodes can be considered sensitive or vulnerable in some network environments. Write operations (e.g., edit-config) to these data nodes without proper protection can have a negative effect on network operations. These are the subtrees and data nodes and their sensitivity/vulnerability:

- rlt-mode: A malicious client could attempt to modify the mode in which the radio link is configured and, thereby, change the intended behavior of the link.
- tx-frequency and channel-separation: A malicious client could attempt to modify the frequency configuration of a carrier, which could modify the intended behavior or make the configuration invalid and, thereby, stop the operation of it.

4. IANA Considerations

IANA has assigned a new URI from the "IETF XML Registry" [RFC3688] as follows:

URI: urn:ietf:params:xml:ns:yang:ietf-microwave-topology

Registrant Contact: The IESG

XML: N/A; the requested URI is an XML namespace.

IANA has recorded the YANG module names in the "YANG Module Names" registry [RFC6020] as follows:

Name: ietf-microwave-topology

Maintained by IANA?: N
Namespace: urn:ietf:params:xml:ns:yang:ietf-microwave-topology
Prefix: mwt
Reference: RFC 9656

5. References

5.1. Normative References

- [RFC3688] Mealling, M., "The IETF XML Registry", BCP 81, RFC 3688, DOI 10.17487/RFC3688, January 2004, <<https://www.rfc-editor.org/info/rfc3688>>.
- [RFC6020] Bjorklund, M., Ed., "YANG - A Data Modeling Language for the Network Configuration Protocol (NETCONF)", RFC 6020, DOI 10.17487/RFC6020, October 2010, <<https://www.rfc-editor.org/info/rfc6020>>.
- [RFC6241] Enns, R., Ed., Bjorklund, M., Ed., Schoenwaelder, J., Ed., and A. Bierman, Ed., "Network Configuration Protocol (NETCONF)", RFC 6241, DOI 10.17487/RFC6241, June 2011, <<https://www.rfc-editor.org/info/rfc6241>>.
- [RFC6242] Wasserman, M., "Using the NETCONF Protocol over Secure Shell (SSH)", RFC 6242, DOI 10.17487/RFC6242, June 2011, <<https://www.rfc-editor.org/info/rfc6242>>.
- [RFC8040] Bierman, A., Bjorklund, M., and K. Watsen, "RESTCONF Protocol", RFC 8040, DOI 10.17487/RFC8040, January 2017, <<https://www.rfc-editor.org/info/rfc8040>>.
- [RFC8341] Bierman, A. and M. Bjorklund, "Network Configuration Access Control Model", STD 91, RFC 8341, DOI 10.17487/RFC8341, March 2018, <<https://www.rfc-editor.org/info/rfc8341>>.
- [RFC8345] Clemm, A., Medved, J., Varga, R., Bahadur, N., Ananthakrishnan, H., and X. Liu, "A YANG Data Model for Network Topologies", RFC 8345, DOI 10.17487/RFC8345, March 2018, <<https://www.rfc-editor.org/info/rfc8345>>.
- [RFC8446] Rescorla, E., "The Transport Layer Security (TLS) Protocol Version 1.3", RFC 8446, DOI 10.17487/RFC8446, August 2018, <<https://www.rfc-editor.org/info/rfc8446>>.
- [RFC8561] Ahlberg, J., Ye, M., Li, X., Spreafico, D., and M. Vaupotic, "A YANG Data Model for Microwave Radio Link", RFC 8561, DOI 10.17487/RFC8561, June 2019, <<https://www.rfc-editor.org/info/rfc8561>>.
- [RFC8795] Liu, X., Bryskin, I., Beeram, V., Saad, T., Shah, H., and O. Gonzalez de Dios, "YANG Data Model for Traffic Engineering (TE) Topologies", RFC 8795, DOI 10.17487/RFC8795, August 2020, <<https://www.rfc-editor.org/info/rfc8795>>.

5.2. Informative References

[EN301129]

- ETSI, "Transmission and Multiplexing (TM); Digital Radio Relay Systems (DRRS); Synchronous Digital Hierarchy (SDH); System performance monitoring parameters of SDH DRRS", EN 301 129 V1.1.2, May 1999, <https://www.etsi.org/deliver/etsi_en/301100_301199/301129/01.01.02_60/en_301129v010102p.pdf>.
- [EN302217-1]** ETSI, "Fixed Radio Systems; Characteristics and requirements for point-to-point equipment and antennas; Part 1: Overview, common characteristics and system-dependent requirements", EN 302 217-1 V3.1.1, May 2017, <https://www.etsi.org/deliver/etsi_en/302200_302299/30221701/03.01.01_60/en_30221701v030101p.pdf>.
- [RFC8340]** Bjorklund, M. and L. Berger, Ed., "YANG Tree Diagrams", BCP 215, RFC 8340, DOI 10.17487/RFC8340, March 2018, <<https://www.rfc-editor.org/info/rfc8340>>.
- [RFC8453]** Ceccarelli, D., Ed. and Y. Lee, Ed., "Framework for Abstraction and Control of TE Networks (ACTN)", RFC 8453, DOI 10.17487/RFC8453, August 2018, <<https://www.rfc-editor.org/info/rfc8453>>.
- [RFC8792]** Watsen, K., Auerswald, E., Farrel, A., and Q. Wu, "Handling Long Lines in Content of Internet-Drafts and RFCs", RFC 8792, DOI 10.17487/RFC8792, June 2020, <<https://www.rfc-editor.org/info/rfc8792>>.
- [RFC8944]** Dong, J., Wei, X., Wu, Q., Boucadair, M., and A. Liu, "A YANG Data Model for Layer 2 Network Topologies", RFC 8944, DOI 10.17487/RFC8944, November 2020, <<https://www.rfc-editor.org/info/rfc8944>>.
- [YANG-BWA-TOPO]** Ahlberg, J., Mansfield, S., Ye, M., Busi, I., Li, X., and D. Spreafico, "A YANG Data Model for Bandwidth Availability Topology", Work in Progress, Internet-Draft, draft-ietf-ccamp-bwa-topo-yang-01, 18 October 2023, <<https://datatracker.ietf.org/doc/html/draft-ietf-ccamp-bwa-topo-yang-01>>.
- [YANG-IF-REF-TOPO]** Ahlberg, J., Mansfield, S., Ye, M., Busi, I., Li, X., and D. Spreafico, "A YANG Data Model for Interface Reference Topology", Work in Progress, Internet-Draft, draft-ietf-ccamp-if-ref-topo-yang-01, 18 October 2023, <<https://datatracker.ietf.org/doc/html/draft-ietf-ccamp-if-ref-topo-yang-01>>.

Appendix A. Microwave Topology Model with Base Topology Models

The tree below shows an example of the relevant leafs for a complete Microwave Topology Model including the augmented Network Topology Model defined in [RFC8345] and the Traffic Engineering (TE) Topologies model defined in [RFC8795]. There are also JSON-based instantiations of the Microwave Topology Model for a couple of small network examples.

```

module: ietf-network
+--rw networks
| +--rw network* [network-id]
| | +--rw network-id          network-id
| | +--rw network-types
| | | +--rw tet:te-topology!
| | | +--rw mwt:mw-topology!
| | +--rw supporting-network* [network-ref]
| | | +--rw network-ref      -> /networks/network/network-id
| | +--rw node* [node-id]
| | | +--rw node-id          node-id
| | | +--rw supporting-node* [network-ref node-ref]
| | | | +--rw network-ref
| | | | | -> ../../../../supporting-network/network-ref
| | | | +--rw node-ref      -> /networks/network/node/node-id
| | +--rw nt:termination-point* [tp-id]
| | | +--rw nt:tp-id          tp-id
| | | +--rw nt:supporting-termination-point*
| | | | [network-ref node-ref tp-ref]
| | | | +--rw nt:network-ref
| | | | | -> ../../../../nw:supporting-node/network-ref
| | | | +--rw nt:node-ref
| | | | | -> ../../../../nw:supporting-node/node-ref
| | | | +--rw nt:tp-ref      leafref
| | +--rw tet:te-tp-id?
| | | te-types:te-tp-id
| | +--rw tet:te!
| | | +--rw tet:name?          string
| | | +--ro tet:geolocation
| | | | +--ro tet:altitude?    int64
| | | | +--ro tet:latitude?
| | | | | geographic-coordinate-degree
| | | | +--ro tet:longitude?
| | | | | geographic-coordinate-degree
| | | +--rw mwt:mw-tp!
| | | | +--rw (mwt:mw-tp-option)?
| | | | | +--:(mwt:microwave-rltp)
| | | | | | +--rw mwt:microwave-rltp!
| | | | | +--:(mwt:microwave-ctp)
| | | | | | +--rw mwt:microwave-ctp!
| | +--rw tet:te-node-id?      te-types:te-node-id
+--rw nt:link* [link-id]
| +--rw nt:link-id            link-id
| +--rw nt:source
| | +--rw nt:source-node?    -> ../../../../nw:node/node-id
| | +--rw nt:source-tp?     leafref
+--rw nt:destination
| +--rw nt:dest-node?       -> ../../../../nw:node/node-id
| +--rw nt:dest-tp?        leafref
+--rw nt:supporting-link* [network-ref link-ref]
| +--rw nt:network-ref
| | -> ../../../../nw:supporting-network/network-ref
| +--rw nt:link-ref          leafref
+--rw tet:te!
| +--rw (tet:bundle-stack-level)?
| | +--:(tet:bundle)
| | | +--rw tet:bundled-links

```

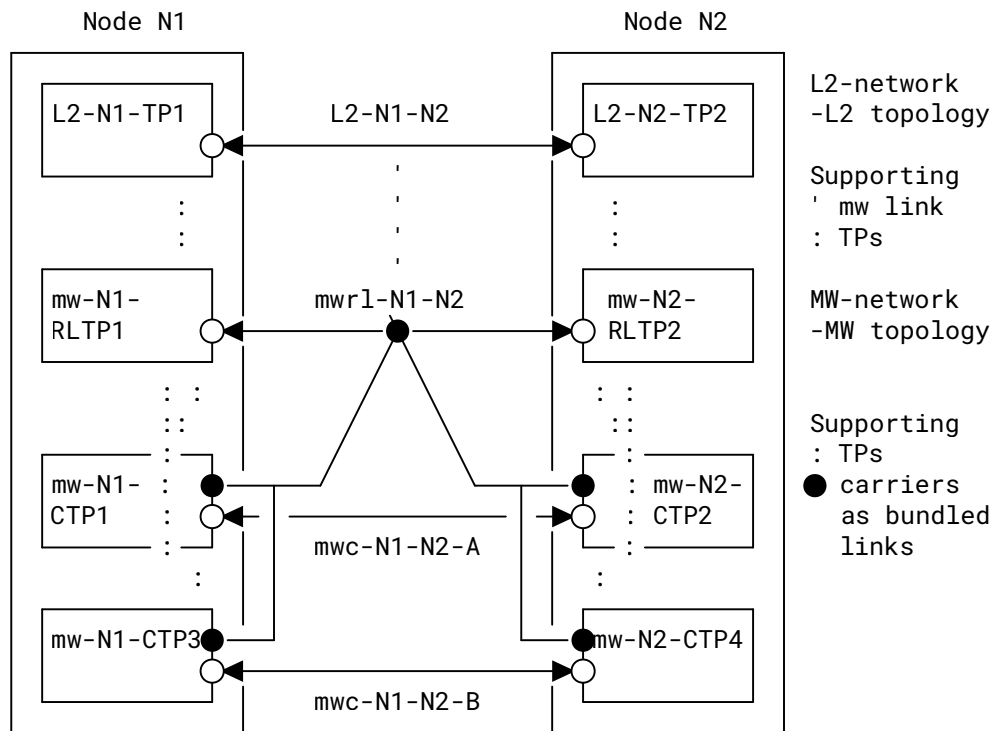



Figure 3: Example for L2 over Microwave

A.1. Instance Data for 2+0 Mode for a Bonded Configuration

An L2 network with a supporting microwave network, showing a 2+0 microwave configuration is provided below. The num-bonded-carriers = 2, and the num-protecting-carriers = 0. This means both carriers are active, so there is no redundancy and there is more capacity. The JSON encoding of the 2+0 example data follows:

```
{
  "ietf-network:networks": {
    "network": [
      {
        "network-id": "L2-network",
        "network-types": {
          "ietf-te-topology:te-topology": {}
        },
        "supporting-network": [
          {
            "network-ref": "mw-network"
          }
        ]
      }
    ],
  }
}
```

```

"node": [
  {
    "node-id": "L2-N1",
    "supporting-node": [
      {
        "network-ref": "mw-network",
        "node-ref": "mw-N1"
      }
    ],
    "ietf-network-topology:termination-point": [
      {
        "tp-id": "L2-N1-TP1",
        "supporting-termination-point": [
          {
            "network-ref": "mw-network",
            "node-ref": "mw-N1",
            "tp-ref": "mw-N1-RLTP1"
          }
        ]
      }
    ]
  },
  {
    "node-id": "L2-N2",
    "supporting-node": [
      {
        "network-ref": "mw-network",
        "node-ref": "mw-N2"
      }
    ],
    "ietf-network-topology:termination-point": [
      {
        "tp-id": "L2-N2-TP2",
        "supporting-termination-point": [
          {
            "network-ref": "mw-network",
            "node-ref": "mw-N2",
            "tp-ref": "mw-N2-RLTP2"
          }
        ]
      }
    ]
  }
],
"ietf-network-topology:link": [
  {
    "link-id": "L2-N1-N2",
    "source": {
      "source-node": "L2-N1",
      "source-tp": "L2-N1-TP1"
    },
    "destination": {
      "dest-node": "L2-N2",
      "dest-tp": "L2-N2-TP2"
    },
    "supporting-link": [
      {
        "network-ref": "mw-network",

```

```

        "link-ref": "mwr1-N1-N2"
      }
    ]
  }
},
{
  "network-id": "mw-network",
  "network-types": {
    "ietf-te-topology:te-topology": {
      "ietf-microwave-topology:mw-topology": {}
    }
  },
  "supporting-network": [
    {
      "network-ref": "mw-network"
    }
  ],
  "node": [
    {
      "node-id": "mw-N1",
      "supporting-node": [
        {
          "network-ref": "mw-network",
          "node-ref": "mw-N1"
        }
      ]
    }
  ],
  "ietf-network-topology:termination-point": [
    {
      "tp-id": "mw-N1-RLTP1",
      "supporting-termination-point": [
        {
          "network-ref": "mw-network",
          "node-ref": "mw-N1",
          "tp-ref": "mw-N1-CTP1"
        },
        {
          "network-ref": "mw-network",
          "node-ref": "mw-N1",
          "tp-ref": "mw-N1-CTP3"
        }
      ]
    },
    {
      "tp-id": "mw-N1-CTP1",
      "ietf-te-topology:te-tp-id": 1,
      "ietf-te-topology:te": {
        "ietf-microwave-topology:mw-tp": {
          "microwave-rltp": {}
        }
      }
    }
  ],
  "ietf-network-topology:termination-point": [
    {
      "tp-id": "mw-N1-CTP1",
      "ietf-te-topology:te-tp-id": 1,
      "ietf-te-topology:te": {
        "ietf-microwave-topology:mw-tp": {
          "microwave-ctp": {}
        }
      }
    }
  ]
},

```

```

    {
      "tp-id": "mw-N1-CTP3",
      "ietf-te-topology:te-tp-id": 2,
      "ietf-te-topology:te": {
        "ietf-microwave-topology:mw-tp": {
          "microwave-ctp": {}
        }
      }
    }
  ],
},
{
  "node-id": "mw-N2",
  "supporting-node": [
    {
      "network-ref": "mw-network",
      "node-ref": "mw-N2"
    }
  ],
  "ietf-network-topology:termination-point": [
    {
      "tp-id": "mw-N2-RLTP2",
      "supporting-termination-point": [
        {
          "network-ref": "mw-network",
          "node-ref": "mw-N2",
          "tp-ref": "mw-N2-CTP2"
        },
        {
          "network-ref": "mw-network",
          "node-ref": "mw-N2",
          "tp-ref": "mw-N2-CTP4"
        }
      ],
      "ietf-te-topology:te-tp-id": "192.0.2.4",
      "ietf-te-topology:te": {
        "ietf-microwave-topology:mw-tp": {
          "microwave-rltp": {}
        }
      }
    },
    {
      "tp-id": "mw-N2-CTP2",
      "ietf-te-topology:te-tp-id": 1,
      "ietf-te-topology:te": {
        "ietf-microwave-topology:mw-tp": {
          "microwave-ctp": {}
        }
      }
    },
    {
      "tp-id": "mw-N2-CTP4",
      "ietf-te-topology:te-tp-id": 2,
      "ietf-te-topology:te": {
        "ietf-microwave-topology:mw-tp": {
          "microwave-ctp": {}
        }
      }
    }
  ]
}

```

```

    }
  ]
}
],
"ietf-network-topology:link": [
{
  "link-id": "mwr1-N1-N2",
  "source": {
    "source-node": "mw-N1",
    "source-tp": "mw-N1-RLTP1"
  },
  "destination": {
    "dest-node": "mw-N2",
    "dest-tp": "mw-N2-RLTP2"
  },
  "ietf-te-topology:te": {
    "bundled-links": {
      "bundled-link": [
        {
          "sequence": 1,
          "src-tp-ref": "mw-N1-CTP1",
          "des-tp-ref": "mw-N2-CTP2"
        },
        {
          "sequence": 2,
          "src-tp-ref": "mw-N1-CTP3",
          "des-tp-ref": "mw-N2-CTP4"
        }
      ]
    }
  },
  "te-link-attributes": {
    "ietf-microwave-topology:mw-link": {
      "microwave-radio-link": {
        "rlt-mode": {
          "num-bonded-carriers": 2,
          "num-protecting-carriers": 0
        }
      }
    }
  }
},
{
  "link-id": "mwc-N1-N2-A",
  "source": {
    "source-node": "mw-N1",
    "source-tp": "mw-N1-CTP1"
  },
  "destination": {
    "dest-node": "mw-N2",
    "dest-tp": "mw-N2-CTP2"
  },
  "ietf-te-topology:te": {
    "te-link-attributes": {
      "ietf-microwave-topology:mw-link": {
        "microwave-carrier": {
          "tx-frequency": 10728000,
          "channel-separation": 28000
        }
      }
    }
  }
}
],
}

```

```

    }
  }
}
},
{
  "link-id": "mwc-N1-N2-B",
  "source": {
    "source-node": "mw-N1",
    "source-tp": "mw-N1-CTP3"
  },
  "destination": {
    "dest-node": "mw-N2",
    "dest-tp": "mw-N2-CTP4"
  },
  "ietf-te-topology:te": {
    "te-link-attributes": {
      "ietf-microwave-topology:mw-link": {
        "microwave-carrier": {
          "tx-frequency": 10528000,
          "channel-separation": 28000
        }
      }
    }
  }
}
]
}
]
}
}
}

```

A.2. Instance Data for 1+1 Mode for a Protected Configuration

An L2 network with a supporting microwave network, showing a 1+1 microwave configuration is provided below. The num-bonded-carriers = 1, and the num-protecting-carriers = 1. This means there is a standby carrier protecting the active carrier. The JSON encoding of the 1+1 example data follows:

```

{
  "ietf-network:networks": {
    "network": [
      {
        "network-id": "L2-network",
        "network-types": {
          "ietf-te-topology:te-topology": {}
        },
        "supporting-network": [
          {
            "network-ref": "mw-network"
          }
        ],
        "node": [
          {
            "node-id": "L2-N1",

```

```

    "supporting-node": [
      {
        "network-ref": "mw-network",
        "node-ref": "mw-N1"
      }
    ],
    "ietf-network-topology:termination-point": [
      {
        "tp-id": "L2-N1-TP1",
        "supporting-termination-point": [
          {
            "network-ref": "mw-network",
            "node-ref": "mw-N1",
            "tp-ref": "mw-N1-RLTP1"
          }
        ]
      }
    ]
  },
  {
    "node-id": "L2-N2",
    "supporting-node": [
      {
        "network-ref": "mw-network",
        "node-ref": "mw-N2"
      }
    ],
    "ietf-network-topology:termination-point": [
      {
        "tp-id": "L2-N2-TP2",
        "supporting-termination-point": [
          {
            "network-ref": "mw-network",
            "node-ref": "mw-N2",
            "tp-ref": "mw-N2-RLTP2"
          }
        ]
      }
    ]
  }
],
"ietf-network-topology:link": [
  {
    "link-id": "L2-N1-N2",
    "source": {
      "source-node": "L2-N1",
      "source-tp": "L2-N1-TP1"
    },
    "destination": {
      "dest-node": "L2-N2",
      "dest-tp": "L2-N2-TP2"
    },
    "supporting-link": [
      {
        "network-ref": "mw-network",
        "link-ref": "mwr1-N1-N2"
      }
    ]
  }
]

```

```

    }
  ]
},
{
  "network-id": "mw-network",
  "network-types": {
    "ietf-te-topology:te-topology": {
      "ietf-microwave-topology:mw-topology": {}
    }
  },
  "supporting-network": [
    {
      "network-ref": "mw-network"
    }
  ],
  "node": [
    {
      "node-id": "mw-N1",
      "supporting-node": [
        {
          "network-ref": "mw-network",
          "node-ref": "mw-N1"
        }
      ]
    }
  ],
  "ietf-network-topology:termination-point": [
    {
      "tp-id": "mw-N1-RLTP1",
      "supporting-termination-point": [
        {
          "network-ref": "mw-network",
          "node-ref": "mw-N1",
          "tp-ref": "mw-N1-CTP1"
        },
        {
          "network-ref": "mw-network",
          "node-ref": "mw-N1",
          "tp-ref": "mw-N1-CTP3"
        }
      ]
    },
    {
      "ietf-te-topology:te-tp-id": "192.0.2.3",
      "ietf-te-topology:te": {
        "ietf-microwave-topology:mw-tp": {
          "microwave-rltp": {}
        }
      }
    }
  ],
  {
    "tp-id": "mw-N1-CTP1",
    "ietf-te-topology:te-tp-id": 1,
    "ietf-te-topology:te": {
      "ietf-microwave-topology:mw-tp": {
        "microwave-ctp": {}
      }
    }
  },
  {
    "tp-id": "mw-N1-CTP3",
    "ietf-te-topology:te-tp-id": 2,

```



```

        "ietf-te-topology:te": {
          "ietf-microwave-topology:mw-tp": {
            "microwave-ctp": {}
          }
        }
      ],
    },
    {
      "node-id": "mw-N2",
      "supporting-node": [
        {
          "network-ref": "mw-network",
          "node-ref": "mw-N2"
        }
      ],
      "ietf-network-topology:termination-point": [
        {
          "tp-id": "mw-N2-RLTP2",
          "supporting-termination-point": [
            {
              "network-ref": "mw-network",
              "node-ref": "mw-N2",
              "tp-ref": "mw-N2-CTP2"
            },
            {
              "network-ref": "mw-network",
              "node-ref": "mw-N2",
              "tp-ref": "mw-N2-CTP4"
            }
          ],
          "ietf-te-topology:te-tp-id": "192.0.2.4",
          "ietf-te-topology:te": {
            "ietf-microwave-topology:mw-tp": {
              "microwave-rltp": {}
            }
          }
        },
        {
          "tp-id": "mw-N2-CTP2",
          "ietf-te-topology:te-tp-id": 1,
          "ietf-te-topology:te": {
            "ietf-microwave-topology:mw-tp": {
              "microwave-ctp": {}
            }
          }
        },
        {
          "tp-id": "mw-N2-CTP4",
          "ietf-te-topology:te-tp-id": 2,
          "ietf-te-topology:te": {
            "ietf-microwave-topology:mw-tp": {
              "microwave-ctp": {}
            }
          }
        }
      ]
    }
  ]
}

```

```

],
"ietf-network-topology:link": [
  {
    "link-id": "mwr1-N1-N2",
    "source": {
      "source-node": "mw-N1",
      "source-tp": "mw-N1-RLTP1"
    },
    "destination": {
      "dest-node": "mw-N2",
      "dest-tp": "mw-N2-RLTP2"
    },
    "ietf-te-topology:te": {
      "bundled-links": {
        "bundled-link": [
          {
            "sequence": 1,
            "src-tp-ref": "mw-N1-CTP1",
            "des-tp-ref": "mw-N2-CTP2"
          },
          {
            "sequence": 2,
            "src-tp-ref": "mw-N1-CTP3",
            "des-tp-ref": "mw-N2-CTP4"
          }
        ]
      }
    },
    "te-link-attributes": {
      "ietf-microwave-topology:mw-link": {
        "microwave-radio-link": {
          "rlt-mode": {
            "num-bonded-carriers": 1,
            "num-protecting-carriers": 1
          }
        }
      }
    }
  },
  {
    "link-id": "mwc-N1-N2-A",
    "source": {
      "source-node": "mw-N1",
      "source-tp": "mw-N1-CTP1"
    },
    "destination": {
      "dest-node": "mw-N2",
      "dest-tp": "mw-N2-CTP2"
    },
    "ietf-te-topology:te": {
      "te-link-attributes": {
        "ietf-microwave-topology:mw-link": {
          "microwave-carrier": {
            "tx-frequency": 10728000,
            "channel-separation": 28000
          }
        }
      }
    }
  }
]

```

```
    },
  },
  {
    "link-id": "mwc-N1-N2-B",
    "source": {
      "source-node": "mw-N1",
      "source-tp": "mw-N1-CTP3"
    },
    "destination": {
      "dest-node": "mw-N2",
      "dest-tp": "mw-N2-CTP4"
    },
    "ietf-te-topology:te": {
      "te-link-attributes": {
        "ietf-microwave-topology:mw-link": {
          "microwave-carrier": {
            "tx-frequency": 10728000,
            "channel-separation": 28000
          }
        }
      }
    }
  }
]
}
```

Appendix B. Microwave Topology Model with Example Extensions

This non-normative appendix provides examples of how the Microwave Topology Model can be used with the interface reference topology (ifref) [YANG-IF-REF-TOPO] and the bandwidth-availability-topology (bwa) [YANG-BWA-TOPO] models. There is also a snippet of JSON to show geolocation information instance data. When the JSON files have long lines, the long lines are wrapped as described in [RFC8792].

The tree below shows an example of the relevant leaves for a complete Microwave Topology Model including interface reference topology (ifref) [YANG-IF-REF-TOPO] and bandwidth-availability-topology (bwa) [YANG-BWA-TOPO] models.

```

module: ietf-network
+--rw networks
  +--rw network* [network-id]
    | +--rw network-id                network-id
    | +--rw network-types
    | | +--rw tet:te-topology!
    | | +--rw mwt:mw-topology!
    | +--rw supporting-network* [network-ref]
    | | +--rw network-ref    -> /networks/network/network-id
    | +--rw node* [node-id]
    | | +--rw node-id                node-id
    | | +--rw supporting-node* [network-ref node-ref]
    | | | +--rw network-ref
    | | | | -> ../../../../supporting-network/network-ref
    | | | +--rw node-ref            -> /networks/network/node/node-id
    | +--rw nt:termination-point* [tp-id]
    | | +--rw nt:tp-id                tp-id
    | | +--rw nt:supporting-termination-point*
    | | | [network-ref node-ref tp-ref]
    | | | +--rw nt:network-ref
    | | | | -> ../../../../nw:supporting-node/network-ref
    | | | +--rw nt:node-ref
    | | | | -> ../../../../nw:supporting-node/node-ref
    | | | +--rw nt:tp-ref            leafref
    | +--rw tet:te-tp-id?
    | | te-types:te-tp-id
    | +--rw tet:te!
    | | +--rw tet:name?                string
    | | +--ro tet:geolocation
    | | | +--ro tet:altitude?          int64
    | | | +--ro tet:latitude?
    | | | | geographic-coordinate-degree
    | | | +--ro tet:longitude?
    | | | | geographic-coordinate-degree
    | | +--rw mwt:mw-tp!
    | | | +--rw (mwt:mw-tp-option)?
    | | | | +--:(mwt:microwave-rltp)
    | | | | | +--rw mwt:microwave-rltp!
    | | | | +--:(mwt:microwave-ctp)
    | | | | | +--rw mwt:microwave-ctp!
    | | | +--rw ifref:tp-to-interface-path?
    | | | | -> /if:interfaces/interface/name
    | +--rw tet:te-node-id?            te-types:te-node-id
  +--rw nt:link* [link-id]
    | +--rw nt:link-id                link-id
    | +--rw nt:source
    | | +--rw nt:source-node?    -> ../../../../nw:node/node-id
    | | +--rw nt:source-tp?      leafref
    | +--rw nt:destination
    | | +--rw nt:dest-node?      -> ../../../../nw:node/node-id
    | | +--rw nt:dest-tp?        leafref
    | +--rw nt:supporting-link* [network-ref link-ref]
    | | +--rw nt:network-ref
    | | | -> ../../../../nw:supporting-network/network-ref
    | | +--rw nt:link-ref          leafref
    | +--rw tet:te!
    | | +--rw (tet:bundle-stack-level)?

```

```

| | | | | +---:(tet:bundle)
| | | | | | +---rw tet:bundled-links
| | | | | | | +---rw tet:bundled-link* [sequence]
| | | | | | | | +---rw tet:sequence uint32
| | | | | | | | +---rw tet:src-tp-ref? leafref
| | | | | | | | +---rw tet:des-tp-ref? leafref
| | | | | +---rw tet:te-link-attributes
| | | | | | +---rw tet:name? string
| | | | | | +---rw tet:max-link-bandwidth
| | | | | | | +---rw tet:te-bandwidth
| | | | | | | | +---ro mwt:mw-bandwidth? uint64
| | | | | +---rw mwt:mw-link!
| | | | | | +---rw (mwt:mw-link-option)
| | | | | | | +---:(mwt:microwave-radio-link)
| | | | | | | | +---rw mwt:microwave-radio-link!
| | | | | | | | | +---rw mwt:rlt-mode
| | | | | | | | | | +---rw mwt:num-bonded-carriers
| | | | | | | | | | | uint32
| | | | | | | | | | +---rw mwt:num-protecting-carriers
| | | | | | | | | | | uint32
| | | | | | | +---:(mwt:microwave-carrier)
| | | | | | | | +---rw mwt:microwave-carrier!
| | | | | | | | | +---rw mwt:tx-frequency?
| | | | | | | | | | uint32
| | | | | | | | | +---ro mwt:actual-rx-frequency?
| | | | | | | | | | uint32
| | | | | | | | | +---rw mwt:channel-separation?
| | | | | | | | | | uint32
| | | | | | | | | +---ro mwt:actual-tx-cm?
| | | | | | | | | | identityref
| | | | | | | | | +---ro mwt:actual-snr?
| | | | | | | | | | decimal64
| | | | | | | | | +---ro mwt:actual-transmitted-level?
| | | | | | | | | | decimal64
| | | | | +---rw bwatopo:link-availability* [availability]
| | | | | | +---rw bwatopo:availability decimal64
| | | | | | +---rw bwatopo:link-bandwidth? uint64
| | | | | +---ro bwatopo:actual-bandwidth?
| | | | | | yang:gauge64

```

Figure 4: Microwave Topology with Extensions Tree

Microwave is a transport technology that can be used to transport client services, such as L2 Ethernet links. When an L2 link is transported over a single supporting microwave radio link, the topologies could be as shown below. Note that the figure just shows an example: there might be other possibilities to demonstrate such a topology. The example of the instantiation encoded in JSON is using only a selected subset of the leaves from the L2 topology model [RFC8944]. The example below uses Figure 3 and adds the interface-related information.

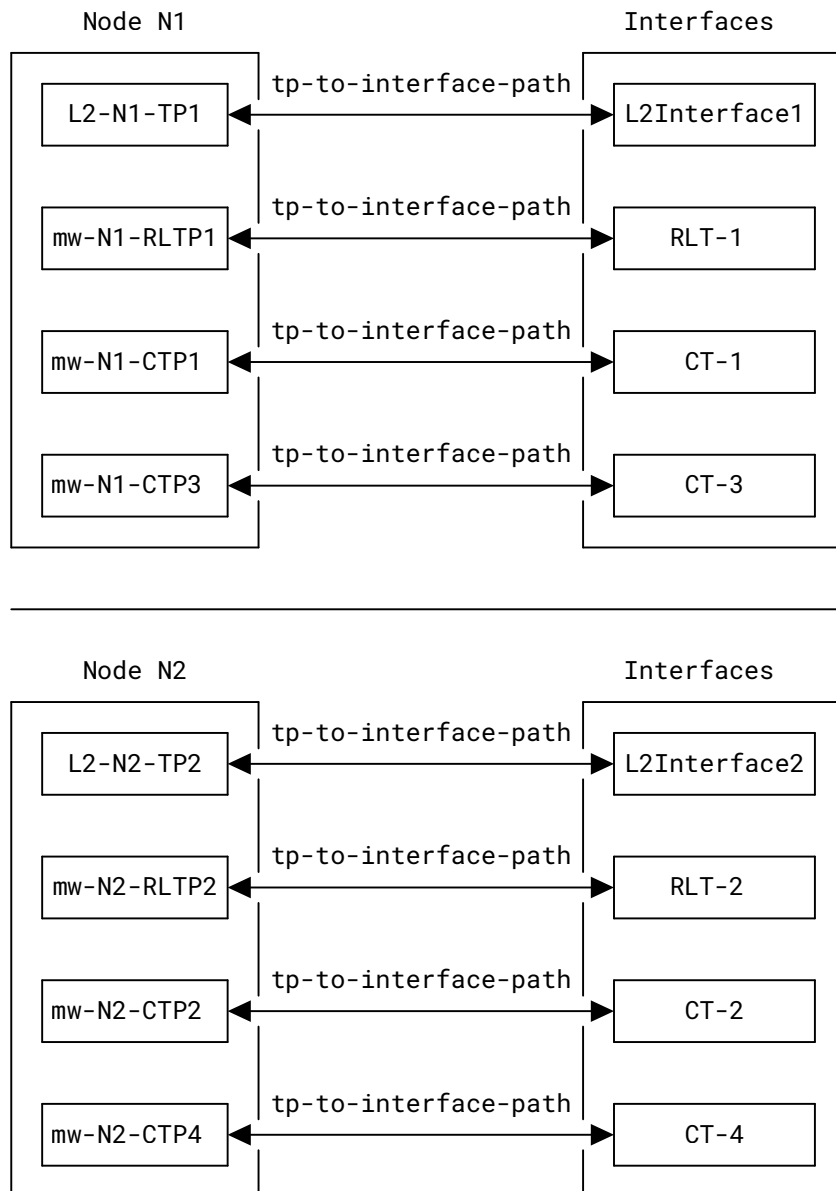

Figure 5: Interface Extension Example for L2 over Microwave

B.1. Instance Data for 2+0 Mode

An L2 network with a supporting microwave network, including microwave-topology (mw) and bandwidth-availability-topology (bwa) models as well as the reference to the associated interface management information, is encoded in JSON as follows:

```
{
  "ietf-interfaces:interfaces": {
    "interface": [
```

```
{
  "name": "L2Interface1",
  "description": "'Ethernet Interface 1'",
  "type": "iana-if-type:ethernetCsmacd"
},
{
  "name": "L2Interface2",
  "description": "'Ethernet Interface 2'",
  "type": "iana-if-type:ethernetCsmacd"
},
{
  "name": "RLT-1",
  "description": "'Radio Link Terminal 1'",
  "type": "iana-if-type:microwaveRadioLinkTerminal",
  "ietf-microwave-radio-link:mode":
    "ietf-microwave-types:two-plus-zero",
  "ietf-microwave-radio-link:carrier-terminations": [
    "CT-1",
    "CT-3"
  ]
},
{
  "name": "RLT-2",
  "description": "'Radio Link Terminal 2'",
  "type": "iana-if-type:microwaveRadioLinkTerminal",
  "ietf-microwave-radio-link:mode":
    "ietf-microwave-types:two-plus-zero",
  "ietf-microwave-radio-link:carrier-terminations": [
    "CT-2",
    "CT-4"
  ]
},
{
  "name": "CT-1",
  "description": "'Carrier Termination 1'",
  "type": "iana-if-type:microwaveCarrierTermination",
  "ietf-microwave-radio-link:tx-frequency": 10728000,
  "ietf-microwave-radio-link:duplex-distance": 113000,
  "ietf-microwave-radio-link:channel-separation": 28000,
  "ietf-microwave-radio-link:rtpc": {
    "maximum-nominal-power": "20.0"
  },
  "ietf-microwave-radio-link:single": {
    "selected-cm": "ietf-microwave-types:qam-512"
  }
},
{
  "name": "CT-3",
  "description": "'Carrier Termination 3'",
  "type": "iana-if-type:microwaveCarrierTermination",
  "ietf-microwave-radio-link:tx-frequency": 10528000,
  "ietf-microwave-radio-link:duplex-distance": 113000,
  "ietf-microwave-radio-link:channel-separation": 28000,
  "ietf-microwave-radio-link:rtpc": {
    "maximum-nominal-power": "20.0"
  },
  "ietf-microwave-radio-link:single": {
    "selected-cm": "ietf-microwave-types:qam-512"
  }
}
```

```

    }
  },
  {
    "name": "CT-2",
    "description": "'Carrier Termination 2'",
    "type": "iana-if-type:microwaveCarrierTermination",
    "ietf-microwave-radio-link:tx-frequency": 10615000,
    "ietf-microwave-radio-link:duplex-distance": 113000,
    "ietf-microwave-radio-link:channel-separation": 28000,
    "ietf-microwave-radio-link:rtpc": {
      "maximum-nominal-power": "20.0"
    },
    "ietf-microwave-radio-link:single": {
      "selected-cm": "ietf-microwave-types:qam-512"
    }
  },
  {
    "name": "CT-4",
    "description": "'Carrier Termination 4'",
    "type": "iana-if-type:microwaveCarrierTermination",
    "ietf-microwave-radio-link:tx-frequency": 10415000,
    "ietf-microwave-radio-link:duplex-distance": 113000,
    "ietf-microwave-radio-link:channel-separation": 28000,
    "ietf-microwave-radio-link:rtpc": {
      "maximum-nominal-power": "20.0"
    },
    "ietf-microwave-radio-link:single": {
      "selected-cm": "ietf-microwave-types:qam-512"
    }
  }
]
},
"ietf-network:networks": {
  "network": [
    {
      "network-id": "L2-network",
      "network-types": {
        "ietf-te-topology:te-topology": {
          "ietf-eth-te-topology:eth-tran-topology": {}
        }
      },
      "supporting-network": [
        {
          "network-ref": "mw-network"
        }
      ],
      "node": [
        {
          "node-id": "L2-N1",
          "supporting-node": [
            {
              "network-ref": "mw-network",
              "node-ref": "mw-N1"
            }
          ]
        }
      ],
      "ietf-network-topology:termination-point": [
        {
          "tp-id": "L2-N1-TP1",

```



```

    "supporting-termination-point": [
      {
        "network-ref": "mw-network",
        "node-ref": "mw-N1",
        "tp-ref": "mw-N1-RLTP1"
      }
    ]
  },
  "ietf-te-topology:te-node-id": "192.0.2.1",
  "ietf-te-topology:te": {
    "te-node-attributes": {
      "ietf-eth-te-topology:eth-node": {}
    }
  },
  {
    "node-id": "L2-N2",
    "supporting-node": [
      {
        "network-ref": "mw-network",
        "node-ref": "mw-N2"
      }
    ],
    "ietf-network-topology:termination-point": [
      {
        "tp-id": "L2-N2-TP2",
        "supporting-termination-point": [
          {
            "network-ref": "mw-network",
            "node-ref": "mw-N2",
            "tp-ref": "mw-N2-RLTP2"
          }
        ]
      }
    ],
    "ietf-te-topology:te-node-id": "192.0.2.2",
    "ietf-te-topology:te": {
      "te-node-attributes": {
        "ietf-eth-te-topology:eth-node": {}
      }
    }
  },
  "ietf-network-topology:link": [
    {
      "link-id": "L2-N1-N2",
      "source": {
        "source-node": "L2-N1",
        "source-tp": "L2-N1-TP1"
      },
      "destination": {
        "dest-node": "L2-N2",
        "dest-tp": "L2-N2-TP2"
      },
      "supporting-link": [
        {
          "network-ref": "mw-network",

```

```

    "link-ref": "mwrl-N1-N2"
  }
],
"ietf-te-topology:te": {
  "te-link-attributes": {
    "interface-switching-capability": [
      {
        "switching-capability": "ietf-te-types:switching-l2sc",
        "encoding": "ietf-te-types:lsp-encoding-ethernet"
      }
    ]
  }
}
}
}
}
},
{
  "network-id": "mw-network",
  "network-types": {
    "ietf-te-topology:te-topology": {
      "ietf-microwave-topology:mw-topology": {}
    }
  },
  "supporting-network": [
    {
      "network-ref": "mw-network"
    }
  ],
  "node": [
    {
      "node-id": "mw-N1",
      "supporting-node": [
        {
          "network-ref": "mw-network",
          "node-ref": "mw-N1"
        }
      ]
    }
  ],
  "ietf-network-topology:termination-point": [
    {
      "tp-id": "mw-N1-RLTP1",
      "supporting-termination-point": [
        {
          "network-ref": "mw-network",
          "node-ref": "mw-N1",
          "tp-ref": "mw-N1-CTP1"
        }
      ],
      {
        "network-ref": "mw-network",
        "node-ref": "mw-N1",
        "tp-ref": "mw-N1-CTP3"
      }
    }
  ],
  "ietf-te-topology:te-tp-id": "192.0.2.3",
  "ietf-te-topology:te": {
    "ietf-microwave-topology:mw-tp": {
      "microwave-rltp": {}
    }
  },
  "ietf-tp-interface-reference-topology:tp-to-interface-path":

```

```

    "RLT-1"
  }
},
{
  "tp-id": "mw-N1-CTP1",
  "ietf-te-topology:te-tp-id": 1,
  "ietf-te-topology:te": {
    "ietf-microwave-topology:mw-tp": {
      "microwave-ctp": {}
    },
    "ietf-tp-interface-reference-topology:tp-to-interface-path":
    "CT-1"
  }
},
{
  "tp-id": "mw-N1-CTP3",
  "ietf-te-topology:te-tp-id": 2,
  "ietf-te-topology:te": {
    "ietf-microwave-topology:mw-tp": {
      "microwave-ctp": {}
    },
    "ietf-tp-interface-reference-topology:tp-to-interface-path":
    "CT-3"
  }
},
],
"ietf-te-topology:te-node-id": "192.0.2.1",
"ietf-te-topology:te": {
  "te-node-attributes": {
    "ietf-microwave-topology:mw-node": {}
  }
},
},
{
  "node-id": "mw-N2",
  "supporting-node": [
    {
      "network-ref": "mw-network",
      "node-ref": "mw-N2"
    }
  ],
  "ietf-network-topology:termination-point": [
    {
      "tp-id": "mw-N2-RLTP2",
      "supporting-termination-point": [
        {
          "network-ref": "mw-network",
          "node-ref": "mw-N2",
          "tp-ref": "mw-N2-CTP2"
        },
        {
          "network-ref": "mw-network",
          "node-ref": "mw-N2",
          "tp-ref": "mw-N2-CTP4"
        }
      ],
      "ietf-te-topology:te-tp-id": "192.0.2.4",
      "ietf-te-topology:te": {

```

```

    "ietf-microwave-topology:mw-tp": {
      "microwave-rltp": {}
    },
    "ietf-tp-interface-reference-topology:tp-to-interface-path":
    "RLT-2"
  }
},
{
  "tp-id": "mw-N2-CTP2",
  "ietf-te-topology:te-tp-id": 1,
  "ietf-te-topology:te": {
    "ietf-microwave-topology:mw-tp": {
      "microwave-ctp": {}
    },
    "ietf-tp-interface-reference-topology:tp-to-interface-path":
    "CT-2"
  }
},
{
  "tp-id": "mw-N2-CTP4",
  "ietf-te-topology:te-tp-id": 2,
  "ietf-te-topology:te": {
    "ietf-microwave-topology:mw-tp": {
      "microwave-ctp": {}
    },
    "ietf-tp-interface-reference-topology:tp-to-interface-path":
    "CT-4"
  }
},
],
"ietf-te-topology:te-node-id": "192.0.2.1",
"ietf-te-topology:te": {
  "te-node-attributes": {
    "ietf-microwave-topology:mw-node": {}
  }
}
],
"ietf-network-topology:link": [
  {
    "link-id": "mwr1-N1-N2",
    "source": {
      "source-node": "mw-N1",
      "source-tp": "mw-N1-RLTP1"
    },
    "destination": {
      "dest-node": "mw-N2",
      "dest-tp": "mw-N2-RLTP2"
    },
    "ietf-te-topology:te": {
      "bundled-links": {
        "bundled-link": [
          {
            "sequence": 1,
            "src-tp-ref": "mw-N1-CTP1",
            "des-tp-ref": "mw-N2-CTP2"
          },
          {

```

```

        "sequence": 2,
        "src-tp-ref": "mw-N1-CTP3",
        "des-tp-ref": "mw-N2-CTP4"
      }
    ]
  },
  "te-link-attributes": {
    "ietf-microwave-topology:mw-link": {
      "microwave-radio-link": {
        "rlt-mode": {
          "num-bonded-carriers": 2,
          "num-protecting-carriers": 0
        }
      }
    }
  }
},
{
  "link-id": "mwc-N1-N2-A",
  "source": {
    "source-node": "mw-N1",
    "source-tp": "mw-N1-CTP1"
  },
  "destination": {
    "dest-node": "mw-N2",
    "dest-tp": "mw-N2-CTP2"
  },
  "ietf-te-topology:te": {
    "te-link-attributes": {
      "ietf-bandwidth-availability-topology:link-availability": [
        {
          "availability": "0.99",
          "link-bandwidth": "998423"
        },
        {
          "availability": "0.95",
          "link-bandwidth": "1048576"
        }
      ],
      "ietf-microwave-topology:mw-link": {
        "microwave-carrier": {
          "tx-frequency": 10728000,
          "channel-separation": 28000
        }
      }
    }
  }
},
{
  "link-id": "mwc-N1-N2-B",
  "source": {
    "source-node": "mw-N1",
    "source-tp": "mw-N1-CTP3"
  },
  "destination": {
    "dest-node": "mw-N2",
    "dest-tp": "mw-N2-CTP4"
  }
}

```

```
    },
    "ietf-te-topology:te": {
      "te-link-attributes": {
        "ietf-microwave-topology:mw-link": {
          "microwave-carrier": {
            "tx-frequency": 10528000,
            "channel-separation": 28000
          }
        }
      }
    }
  ]
}
```

B.2. Instance Data for Geolocation Information

This example provides a JSON snippet that shows geolocation information.

```
"node": [
  {
    "node-id": "mw-N1",
    ...
    "ietf-te-topology:te" : {
      "ietf-te-topology:geolocation": {
        "altitude": "200000",
        "latitude": "45",
        "longitude": "90"
      }
    },
    "ietf-network-topology:termination-point": [
      ...
    ]
  }
]
```

Acknowledgments

This document was initially prepared using the kramdown RFC tool written and maintained by Carsten Bormann. Thanks to Martin Thomson for the GitHub integration of the kramdown RFC tool and for the aasvg tool, which is used for the ascii-to-SVG conversion.

The authors would like to thank Tom Petch, Éric Vyncke, and Rob Wilton for their reviews.

Contributors

Italo Busi

Huawei Technologies

Email: italo.busi@huawei.com

Authors' Addresses

Scott Mansfield (EDITOR)

Ericsson Inc

Email: scott.mansfield@ericsson.com

Jonas Ahlberg

Ericsson AB

Lindholmspiren 11

SE-417 56 Goteborg

Sweden

Email: jonas.ahlberg@ericsson.com

Min Ye

Huawei Technologies

No.1899, Xiyuan Avenue

Chengdu

611731

China

Email: amy.yemin@huawei.com

Xi Li

NEC Laboratories Europe

Kurfursten-Anlage 36

69115 Heidelberg

Germany

Email: Xi.Li@neclab.eu

Daniela Spreafico

Nokia - IT

Via Energy Park, 14

20871 Vimercate (MI)

Italy

Email: daniela.spreafico@nokia.com